



YZF R3 WSSP 300

GYTR ENGINE KIT MANUAL

FIM approved parts 2019

SUPERSPORT300 ◀
FIM WORLD CHAMPIONSHIP

March 2019

Contents

1	General Information.....	2
	1.1.1 How to use this manual.....	3
	1.1.2 Disclaimer of warranty.....	3
	1.1.3 Technical disclaimer.....	3
	1.1.4 Engine Specification.....	4
2	Engine Upgrade kit part list.....	5
	2.1 Camshafts.....	5
	2.1.1 Cams sprockets.....	5
	2.2 Seat valve spring.....	6
	2.3 Gaskets.....	6
	2.4 Piston.....	7
	2.5 Air Funnels.....	8
3	Hint/Note.....	9

1 General information

1.1 How to use this manual

This manual is intended for people with knowledge and experience in the assembly of motorcycle engines. For information on the assembly and maintenance of parts not mentioned in this manual, refer to the YZF-R3 service manual (cod: B7P-F8197-E0) and to the YZF-R3 parts catalogue (cod:1UB7P-300E1) published by YAMAHA MOTOR CO.

The design of the YZF-R3 engine upgrade kit is based on the YZF-R3, according to the FIM WSBK competition technical regulations, but this does not mean that the kit complies with other competition technical rules. When used in different competitions other than WSSP 300, teams use the kit parts at their own responsibility after checking the specific competition regulations issued.

1.2 Disclaimer of warranty

PLEASE NOTE THAT THESE PARTS ARE COVERED BY STANDARD GYTR WARRANTY.

THE MANUFACTURER ASSUMES NO RESPONSIBILITY FOR ANY PROBLEMS CAUSED BY THESE PARTS AFTER ASSEMBLY.

1.3 Technical disclaimer

These parts of the kit are intended exclusively for competition use. It is strongly requested not to use the mentioned kit on public roads.

Technical data, methods of use of these kit's parts and contents of this manual are subject to change without notice for improvement of performance



1.4 Engine Specifications

Year		2019	2019	2018	2017
Spec		WSSP 300 /FIM-SBK tec. regulation	YZF R3 / B7P	YZF R3 / BR5	YZF R3 / BR0
Displacement		321 cm³	321 cm ³	321 cm ³	321 cm ³
Bore X Stroke		68.0 X 44.1	68.0 X 44.1	68.0 X 44.1	68.0 X 44.1
Maximum engine speed (limiter controlled speed)		13.000 rpm	12200 rpm	12200 rpm	12200 rpm
Compression ratio (recommended value) - Depending on head surface grinding		12.1-12.3:1 *	11.2:1	11.2:1	11.2:1
Valve timing (event angle)	IN	113° *	-	-	-
	EXH	113° *	-	-	-
Valve - piston clearance	IN	1 mm * @ 10°	-	-	-
	EXH	1.6 mm * @ 10°	-	-	-
Valve (tappet) clearance	IN	0.13 – 0.15 mm	0.11 - 0.18 mm	0.11 - 0.18 mm	0.11 - 0.18 mm
	EXH	0.15 – 0.20 mm	0.25 - 0.32 mm	0.25 - 0.32 mm	0.21 - 0.30 mm

NOTICE

*The data are indicative and detected with the new engine

2 Engine kit part list

Part Number	Part Name	Quantity	Comment
B7PE2170-RC-00	Shaft, Cam 1 Intake	1	New design and material
B7PE2180-RC-00	Shaft, Cam 2 Exhaust	1	New design and material
B7P-E2176-RC-00	Cam Sprocket	2	With slotted holes
B7P-E1631-RC-00	Piston	2	Race spec
B7P-E1181-RC-00	Gasket 1, cylinder head	1	Thickness 0.20 mm
B7P-E1351-RC-00	Gasket 2, cylinder	1	Thickness 0.10 mm
B7P-E3750-RC-00	Air Funnel	2	CNC machined, high strength aluminium
B7P-E2126-RC-00	Seat valve spring Intake	4	Thickness 0.8 mm vs STD
B7P-RACE3-19-00	Full engine kit YZF-R3 '19	1	Available for Model EURO4 – EURO3

2.1 Camshafts

Part Number	Part Name	Quantity	Comment
B7P-E2170-RC-00	SHAFT, CAM 1 INTAKE	1	New design and material
B7P-E2180-RC-00	SHAFT, CAM 2 EXHAUST	1	New design and material
B7P-E2176-RC-00	CAM SPROCKET	2	With slotted holes

2.1.1 Cams sprockets

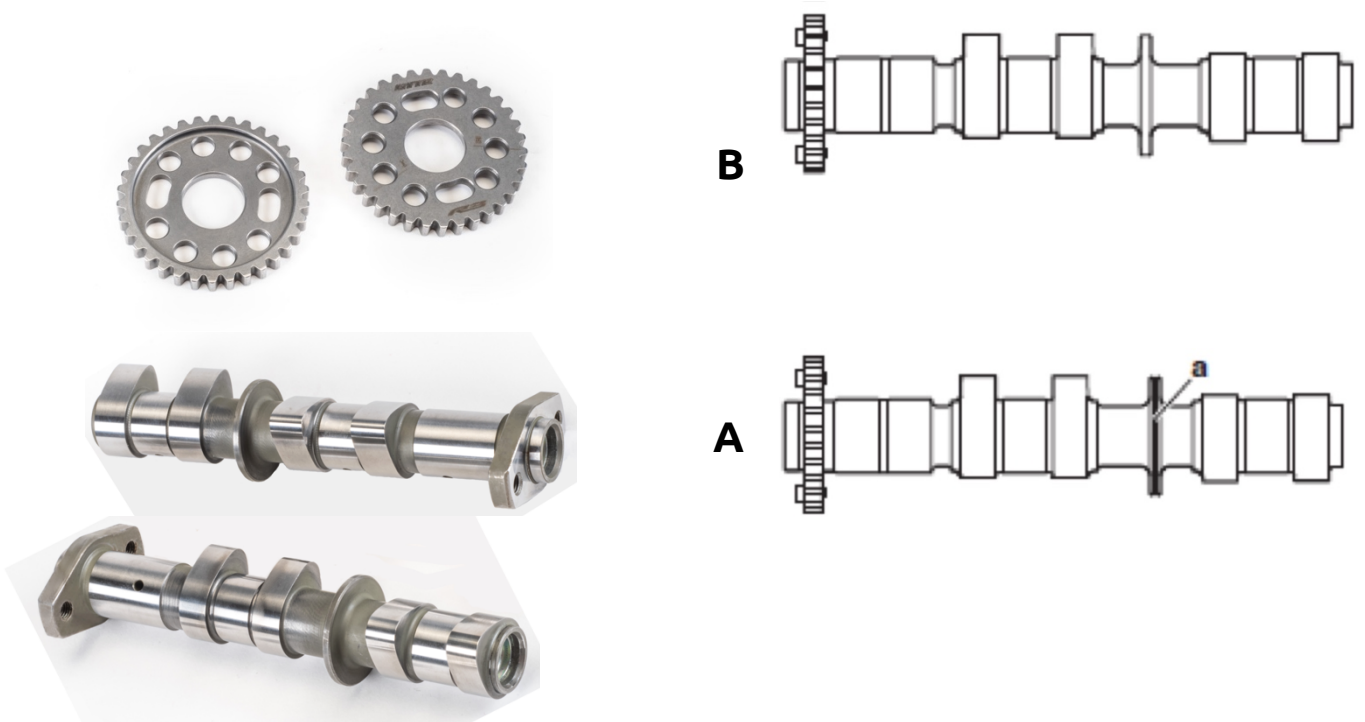

- A. Shaft, Cam 2 Exhaust B7PE2180-RC-00 – Cam Sprocket B7P-E2176-RC-00**
B. Shaft, Cam 1 Intake B7PE2170-RC-00 - Cam Sprocket B7P-E2176-RC-00

Assembly Procedure different to the OEM:

Fit the cams as per standard procedure; check and adjust the timing to the correct values with new cams sprockets ; then lock the bolts applying a torque of 20 Nm (2.0 Kgf – 15lbft), using a torque wrench.

For all the rest please refer to B7P-F8197-E0 service manual.

2.2 Seat valve spring

Intake valve - seat valve spring, add new 4 seat valve thickness (+0,8 mm vs STD) in order to have more spring preload. Keep under control the positive/negative spring damping.

Part Number	Part Name	Quantity	Comment
B7P-E2126-RC-00	Seat valve spring Intake	4	Thickness 0.8 mm vs STD

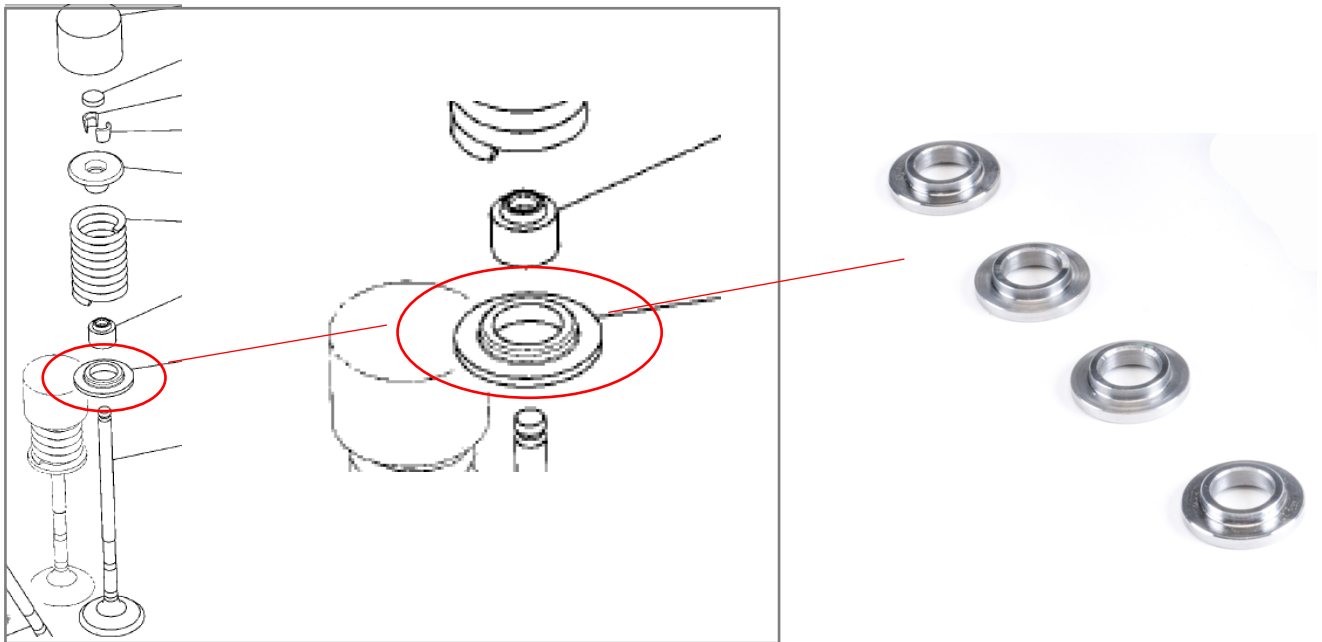

2.3 Gaskets

New gaskets on the base of cylinder 0,10 mm (B7P-E1351-RC-00) and cylinder head 0,20 mm (B7P-E1181-RC-00).

Part Number	Part Name	Quantity	Comment
B7P-E1181-RC-00	Gasket 1, cylinder head	1	Thickness 0.20 mm
B7P-E1351-RC-00	Gasket 2, cylinder	1	Thickness 0.10 mm

1



2

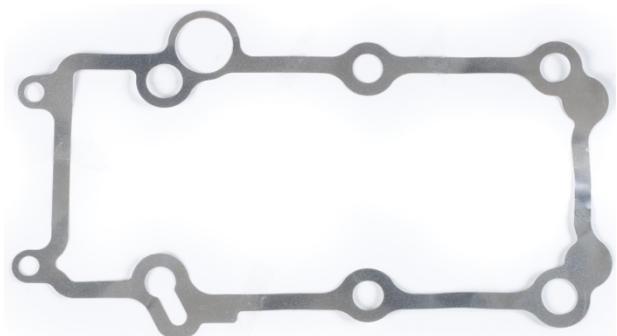

2.4 Piston

New forged piston with anti-friction material. Assembly with STD pistons ring set (BR5-E1603-00) and pin piston (1WD-E1603-00) as well.

Recommended

- **break-in: 250 km (50 Km < 6.000 rpm/throttle 40% – 100 km < 8.000 rpm / throttle 50% – 70 km < 10.000 rpm / throttle 60% – 30 km < 11.500 rpm / throttle 75%) it's advised to keep varying throttle and RPM during the break-in process.**
- **Before the starting the proceed to be sure water temperature must be minimum 70°**
- **Keep STD thermostat valve mounted.**

Part Number	Part Name	Quantity	Comment
B7P-E1631-RC-00	Piston	2	Race spec



Attention :

Check the tolerance Cylinder / Piston	0,045<0,065 mm	
Valve - piston clearance	IN	1 mm * @10°
	EXH	1.6 mm * @10°

2.5 Air Funnels

Part Number	Part Name	Quantity	Comment
B7P-E3750-RC-00	Air Funnel	2	CNC machined, high strength aluminium

Assembly Procedure & Design:

Attention, before to apply the new Air funnels code B7P-E3750-RC-00 cut 2MS-E4469-00 & 2MS-E446C-00 at the base of the throttle body, after that, insert the new aluminium part with interference till the stopper.



3 Hint / Note

Take care the break-in for the engine in order to have a best and safe set up.

Valve piston clearance respect the data

Kit has been tested with ECU STD plus add module and WSSP300 ECU kit system.

Kit it has been developed with the exhaust system : Akrapovic V-VZOREC Racing Line WSSP300

During engine assembly it is recommended to keep everything clear and tidy.

To avoid making mistakes it is advisable to keep the replaced parts separate from the parts of the kit. Keep also note of mounted components by recording everything including the mileage of each part.

When parts are reused, clean and check for damage, deterioration or excessive wear.

Thanks for your attention, get all the best in your racing season.

Kits and Spare Parts will be available by Yamaha Motor Europe

Parts & Accessory division : P&ACustomerSupport@YAMAHA-MOTOR.NL